

# 4-IN-1 Multi-Purpose Buckets

For skid-steer loaders

## FEATURES:

- 66" & 72" Utility Grade widths available and 72", 78" & 84" Construction Grade widths available
- With or without teeth available
- Functions as a loader bucket, clam, dozer, scraper and bottom dump bucket
- Heavy duty hinges and pins to distribute load
- Hose Saver Spring Kit is standard
- Optional spill guard, cylinder covers, tooth bars and bolt on edges
- 1 year limited warranty

 **BRADCO**

 **FFC**

 **HARLEY**

 **THE MAJOR**

 **McMILLEN**

 **SWEEPSTER**

**PALADIN** LIGHT CONSTRUCTION



Construction Grade  
Shown with optional side cutters and spill guard



Utility Grade

# 4-IN-1 Multi-Purpose Buckets

Specifications	Utility Grade		Construction Grade		
	MP66	MP72	MP72	MP78	MP84
Order Codes (w/o teeth)	108018	108020	108022	108024	108026
Order Codes (with teeth)	108019	108021	108023	108025	108027
A. Width (overall)	66.96"	72.96"	72.75"	78.75"	84.75"
B. Height (overall)	27.32"	27.32"	27.57"	27.57"	27.57"
C. Length (overall)	34.47"	34.47"	38.13"	38.13"	38.13"
D. Clam Length	23.06"	23.06"	26.67"	26.67"	26.67"
E. Back Blade Length	12.36"	12.36"	12.41"	12.41"	12.41"
F. Clamp Opening	34.64"	34.64"	34.79"	34.79"	37.79"
Operating Pressure (PSI)	2250	2250	2250	2250	2250
Clamping Force (lbs)	2354	2354	4011	4011	4011
Weight	620	655	900	935	975
Heaped Capacity (cu/ft)	15.76	17.23	19.99	21.69	23.40
Cylinder Specifications					
Bore	2.00"	2.00"	2.50"	2.50"	2.50"
Stroke	7.50"	7.50"	7.50"	7.50"	7.50"
Rod Diameter	1.12"	1.12"	1.25"	1.25"	1.25"

Optional spill guard, cylinder covers, tooth bars and bolt-on edges available.

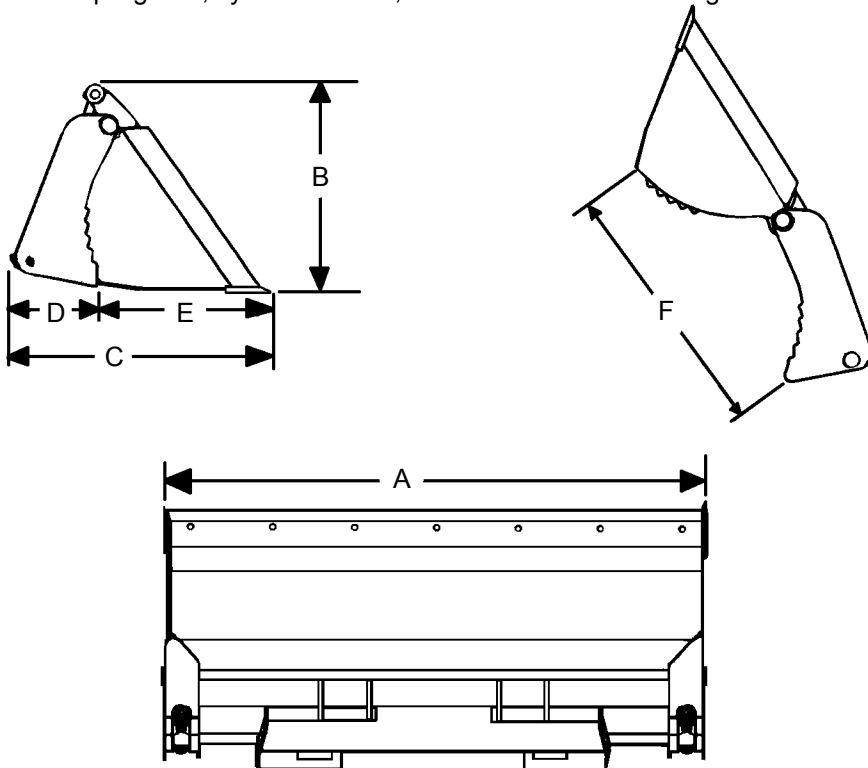

Specifications and design are subject to change without notice and without liability, therefore, whenever applicable specifications are in accordance with SAE standards.

## FEATURES:

### UTILITY & CONSTRUCTION GRADES

- Conventional or bottom dump buckets allows the operator to dump into high side board trucks
- Long-floor design improves cutting edge visibility, for maximum accuracy when grading
- Constructed of high tensile material for reduced weight and higher strength
- Optional removable spill plate for improved visibility

### CONSTRUCTION GRADE

- Dual check valve
- Spherical bushings on cylinder ends
- 1" x 6" cutter edge on front of clam and 3/4" x 6" high carbon edge on rear of clam
- Optional side cutters
- Optional bolt-on tooth bars
- Optional bolt-on tooth bar that will fit with bolt on edge

PH: (800) 922-2981  
FX: (563) 922-2700

P.O. Box 266  
Delhi, IA 52223-0266  
United States of America

[www.paladinbrands.com](http://www.paladinbrands.com)

B - 4-in-1 Bucket 0705-1

