

# Pallet Forks

For Skid-Steer Loaders

**FEATURES:**

- Heavy duty frame designed to handle 4,000 - 6,000 lb capacities depending on tine option
- Heavy gage brick guard offers outstanding strength and smooth surfaces for protection against load damage
- Excellent see through visibility allows the operator to see tine ends
- 36", 42", & 48" tines available
- Optional features include: Auger Mount, Bale Spear, & 2" Trailer Receiver Hitch
- 2 year limited warranty

*Signature Series*  
custom models are available.



Exclusive load retention hook for securing and position pallet fork loads.  
*Patent #6,881,023*

Easy operator access is assured with a convenient non-skid step.



PALADIN LIGHT CONSTRUCTION



Auger Mount



Bale Spear



Receiver Hitch

# Pallet Fork

## FEATURES:

- Excellent visibility and see through brick guard
- Optional personalized name or logo cut into frame
- Angled side corners and side step for easy and safe entrance in and out of loader
- Patented pull "D" ring or load retention tie down can be used to pull loads out of trucks, retain loads, and much more
- Several pallet fork tine sizes available:
  - 3300# in 42" & 48"
  - 4000# in 36", 42" & 48"
  - 5500# in 42" & 48"
  - 6000# in 42" & 48"
- Optional auger mount for the McMillen auger drives
- Optional 2" trailer receiver hitch
- Optional 2 or 3 spear bale carrier available:
  - 2 spear is 48" long x 1 3/4" dia. & (1) 20" long x 1 1/4" dia. stabilizer tine
  - 3 spear is 48" long x 1 3/4" dia. & (2) 20" long x 1 1/4" dia. stabilizer tines
- 2 year limited warranty

Specifications	Standard	Extended
A. Height (overall)	38.75"	38.75"
B. Width (overall)	45.88"	65.75"
C. Adjustable Tine Spacing (maximum)	45.00"	60.00"
D. Adjustable Tine Spacing (minimum)	9.00"	9.00"
E. ITA Category II Fork Mounting	16.00"	16.00"

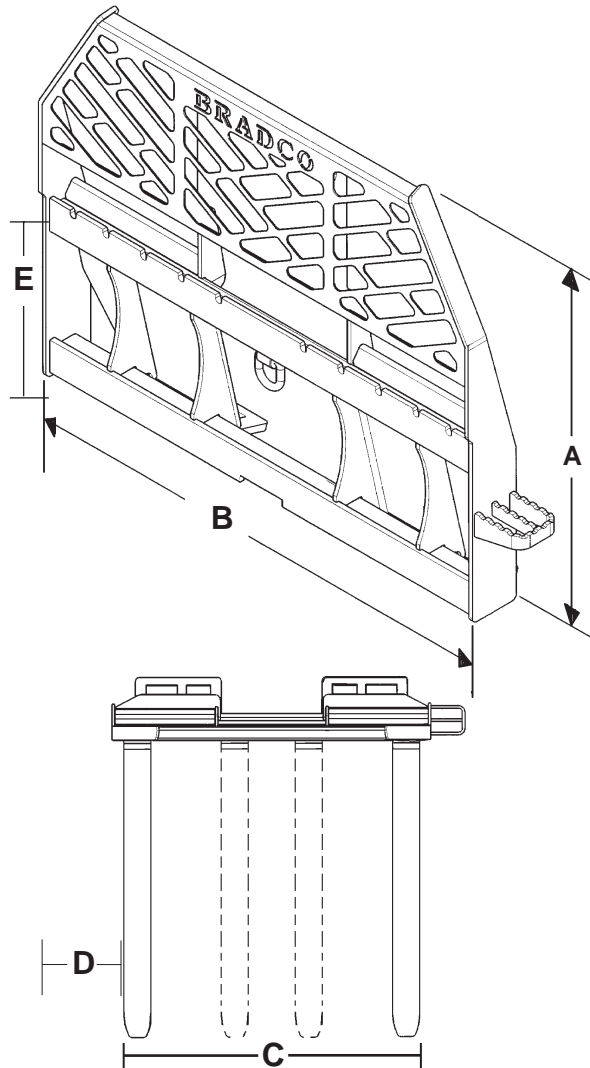

Specifications and design are subject to change without notice and without liability, therefore, whenever applicable specifications are in accordance with SAE standards.

PH: (800) 922-2981  
FX: (563) 922-2700

P.O. Box 266  
Delhi, IA 52223-0266  
United States of America

[www.paladinbrands.com](http://www.paladinbrands.com)

B-Pallet Fork 06011-4



PALADIN LIGHT CONSTRUCTION